

PR

系列 調壓閥(附止逆功能)

PÖSU
PNEUMATIC

series **REGULATOR** (With Back Flow Mechanism)



Symbol

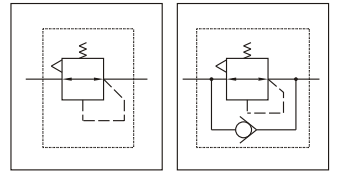

本體材質鋁合金壓鑄

The body is made of die casting aluminum alloy.

規格表 Specifications

型式 Type	PR2000	PRL2000	PRN2000	PR3000(C)	PR4000(C)
接管口徑 Port size (G)	1/8", 1/4"			1/4", 3/8"	1/2, 3/4"
壓力錶接管口徑 Port size for pressure gauge (G)	1/8"			1/8"	1/4"
使用流體 Fluid	空氣 Air				
保證耐壓力 Proof pressure (kgf/cm ²)	15				
最大使用壓力 Max. operating pressure (kgf/cm ²)	9.9	3.2	9.9	10.2	
調壓範圍 Regulating range (kgf/cm ²)	0.5 ~ 8.5	0.2 ~ 2	0.3 ~ 7	0.5 ~ 8.5	
環境和介質溫度 Ambient and media temperature (°C)	-5 ~ 60(無凍結狀態)With no freezing				
油杯材質 Bowl material	聚碳酸酯 Polycarbonate				
重量 Weight (kg)	0.16			0.4	0.8

選配零件/附屬裝置 Accessory (Optional) / Attachment

名稱 Name	型式 Type	零件型式 Part No.					參考頁數 Reference Page	
		PR2000	PRL2000	PRN2000	PR3000(C)	PR4000(C)		
PR/PW用安裝架 (Bracket)		W335			W423	W522	A-35	
壓力錶 Pressure gauge	10 kgf/cm ²	圓形 Round	K40110			K40110	K40210	A-36
		方形 Square	GK27510			GK27510	GK27510	A-36
	4 kgf/cm ²	圓形 Round	K40104			K40104	K40204	A-36

訂購代號 Order No.

PR 3000 C 03 K W

- PR** 調壓閥 Regulator
- 3000** 型式 Type
 - 2000
 - 3000
 - 4000
- C** 附止逆功能 With back flow mechanism
 - 標準調壓閥 Standard regulator
 - C** 附止逆功能 With back flow mechanism

● 1/2", 3/4"一律附止逆功能。
● 1/2", 3/4" All series with back-flow mechanism.
- 03** 接管口徑 Port size
 - 01 1/8"
 - 02 1/4"
 - 03 3/8"
 - 04 1/2"
 - 06 3/4"
- K** 壓力錶 Pressure gauge
 - 不附錶 Without gauge
 - K** 圓形 Round
 - GK** 方形 Square
- W** 安裝架 Bracket
 - 不附托架 Without bracket
 - W** 附托架 With bracket

Regulator

尺寸圖 Dimension

PR2000



PRL2000

PRN2000

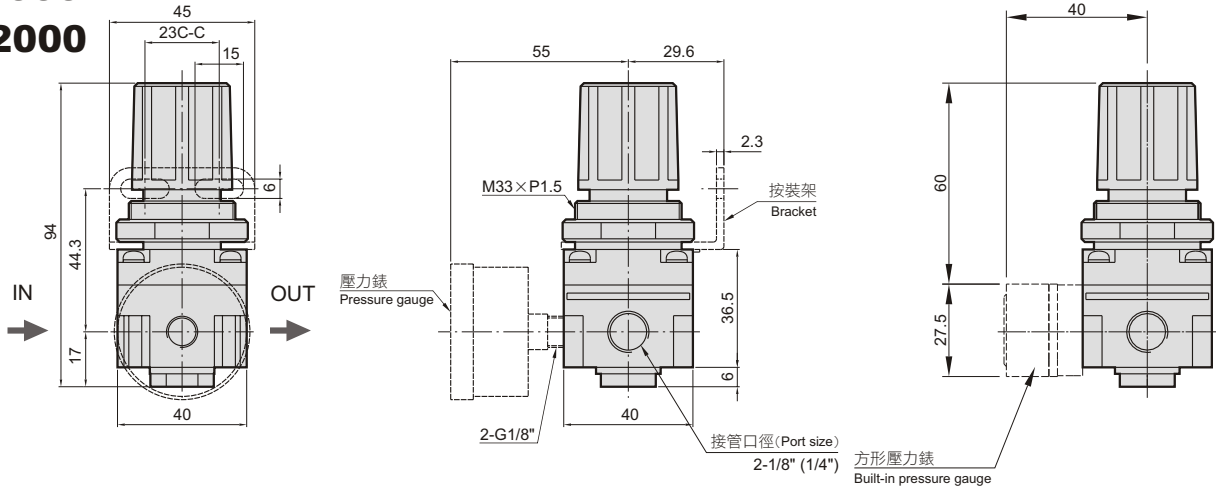

PR3000(C)

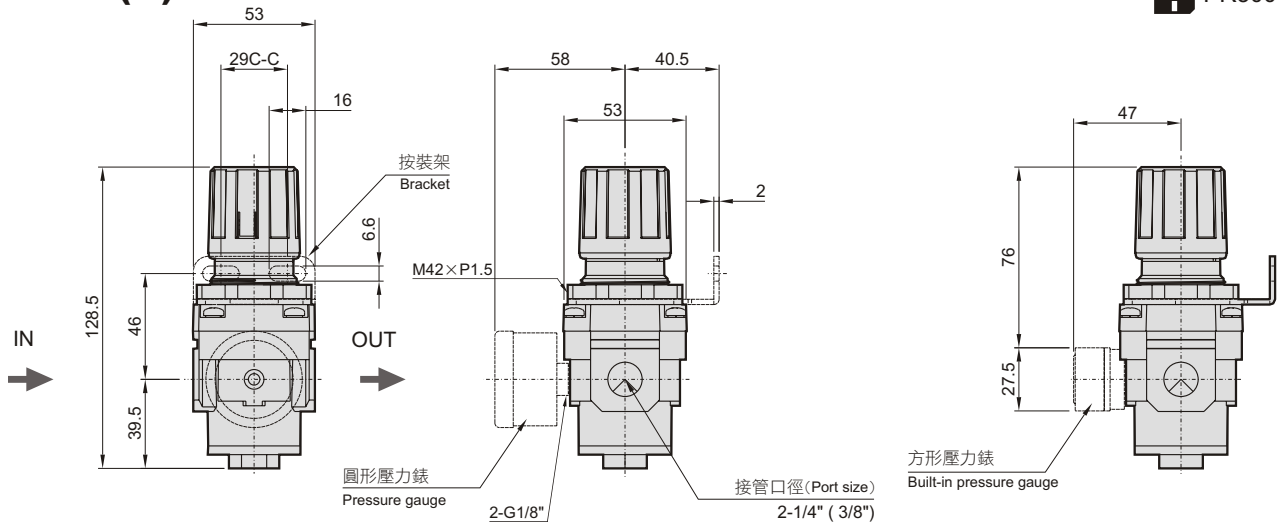
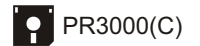

PR4000(C)

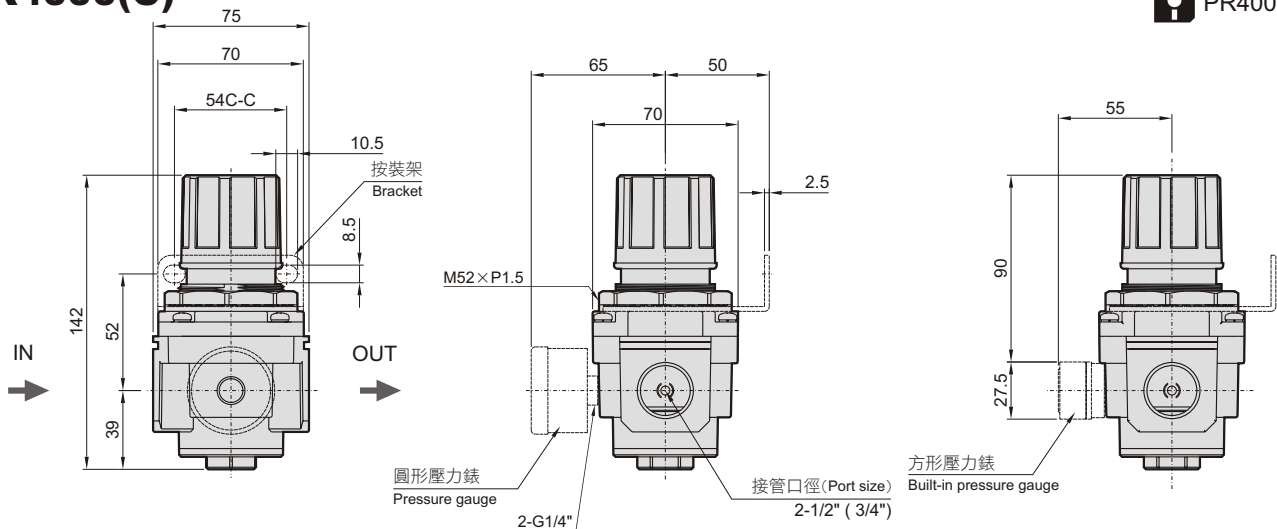

Regulator

流量特性 Flow Characteristics

PR2000, PRL2000, PRN2000 G 1/4"

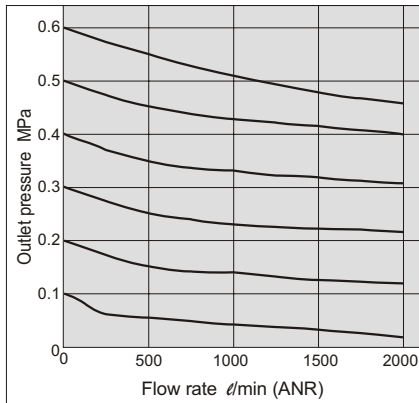

PR3000(C) G 3/8"

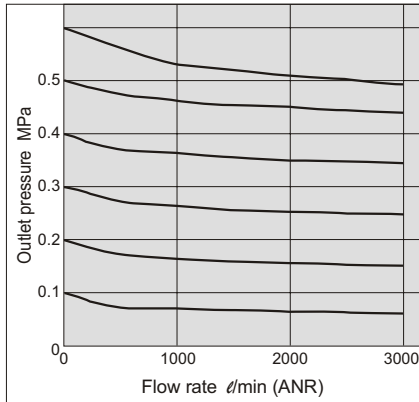

PR4000(C) G 1/2"

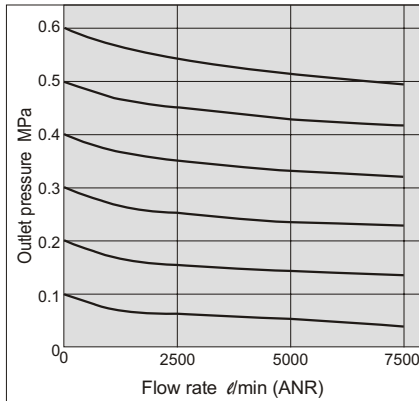

PR4000-06 G 3/4"

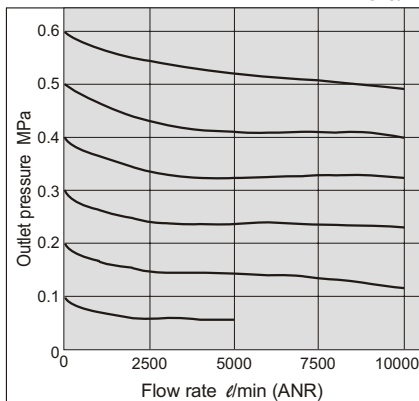

壓力特性 Pressure Characteristics

PR2000, PRL2000, PRN2000

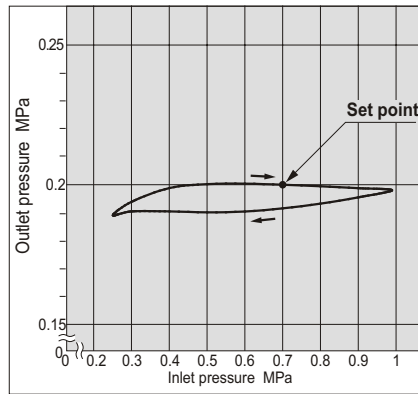

PR3000(C)

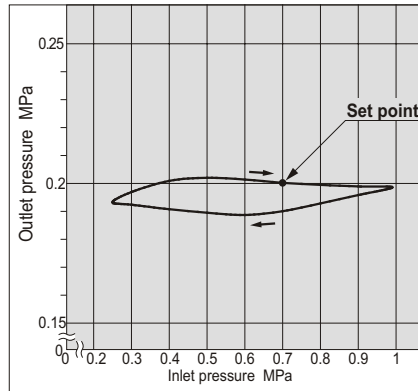

PR4000(C)

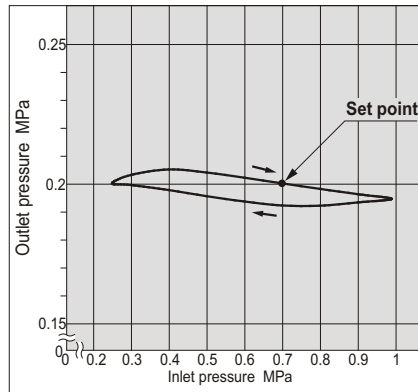

PR4000-06

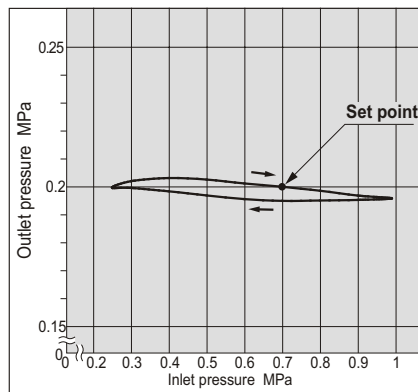

使用注意事項 Specific Product Precautions

安裝、調整

警告

- ①請確定一次側壓力與二次側之壓力計的表示壓力後，再進行設定。
若旋轉旋鈕過度的話，則會造成內部零件破損。
- ②操作調壓旋鈕時，由於使用工具會造成損壞，請採手動方式。

注意

- 壓力調整，須於旋鈕的定位解除後進行，而調整後，請再鎖定。

若步驟錯誤的話，則可能導致旋鈕破損與二次側壓力改變。

- ①請引出調壓旋鈕時，則定位解除。(調壓旋鈕下側的『橘色線』，可以目視確認。)



- ②按下調壓旋鈕時，則鎖定。如果不易鎖定时，請左右旋轉，再按下。(『橘色的線』消失。)

Mounting & Adjustment

Warning

- ①Set the regulator while verifying the displayed values of the inlet and outlet pressure gauges. Turning the knob excessively can cause damage to the internal parts.
- ②Do not use tools on the pressure regulator knob as this may cause damage. It must be operated manually.

Caution

- Be sure to unlock the knob before adjusting the pressure and lock it after setting the pressure.

Failure to follow this procedure can cause damage to the knob and the outlet pressure may fluctuate.

- ①Pull the pressure regulator knob to unlock. (You can visually verify this with the "orange mark" that appears in the gap.)

- ②Push the pressure regulator knob to lock. When the knob is not easily locked, turn it left and right a little and then push it (when the knob is locked, the "orange mark", i.e., the gap will disappear).